

VASAGLE®

---

# LSB47/047

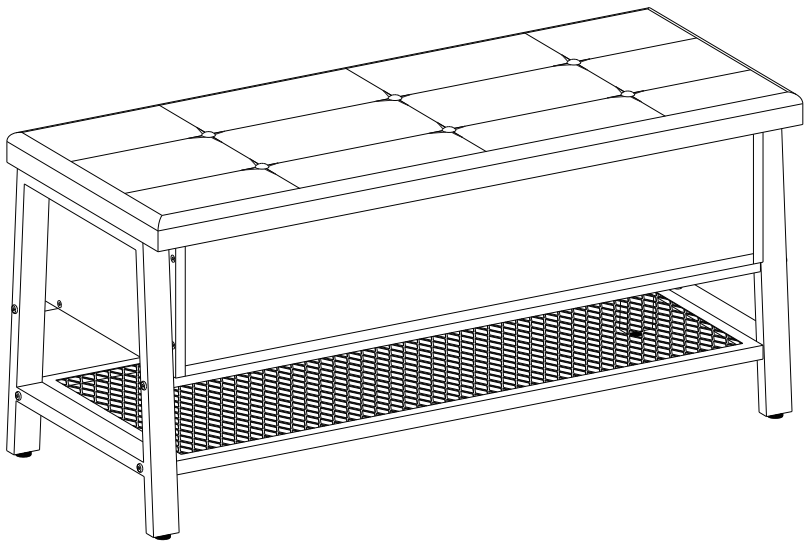

by SONGMICS

## General Guidelines

- Please read the following instruction carefully and use the product accordingly.
- Please keep this manual and hand it over when you transfer the product.
- This summary may not include every detail of all variations and considered steps. Please contact us when further information and help are needed.

## Notes

- This product should only be used indoors. The user must assemble and use the product strictly according to the instructions; it is not allowed to alter or renovate the item arbitrarily, which may cause personal injury or product damage. The seller does not assume any responsibility or liability with respect to any damage caused by incorrect assembly or improper use.
- Do not place the product in a humid environment for an extended period of time to prevent it from mildewing.
- During assembly, loosely tighten the screws; when the assembly is completed, you can tighten all of the screws.
- Check the tightness of the screws regularly. As the product is used over time, the screws may gradually become loose, which may cause damage as a result of toppling, so make sure the screws are properly tightened.

## Warnings

- During assembly, keep all small objects out of the reach of children, as they may be fatal if swallowed or inhaled.
- Never allow children to climb or play around the product in order to protect children from injury caused by tilting of the product.
- To avoid the potential dangers of suffocation, please keep all parts and packaging away from children.
- Do not expose the product to sharp objects and corrosive substances to avoid product damage or personal injury.
- The product can hold up to 440 lbs (200 kg). Do not place any overweight items on it.

## Einleitung

- Bitte lesen Sie die folgende Anleitung aufmerksam durch und verwenden Sie das Produkt sachgemäß.
- Bewahren Sie diese Anleitung gut auf und händigen Sie sie bei Weitergabe des Produkts an Dritte ebenfalls mit aus.
- Aus Gründen der Übersicht können nicht alle Details zu allen Varianten und denkbaren Montagen beschrieben werden. Wenn Sie weitere Informationen und Hilfe benötigen, kontaktieren Sie uns bitte.

## Hinweise

- Dieses Produkt ist nur für den Gebrauch in Innenräumen vorgesehen. Eine andere Verwendung als beschrieben, oder eine Veränderung/ein Umbau des Produkts ist nicht erlaubt und kann zu Verletzungen und/oder Beschädigungen des Produkts führen. Der Händler übernimmt keine Haftung für Schäden, die durch unsachgemäßen Gebrauch oder falsche Montage entstanden sind.
- Halten Sie das Produkt nicht langfristig in einer feuchten Umgebung, um Schimmel zu vermeiden.
- Ziehen Sie die Schrauben bitte zuerst nicht an. Nachdem Sie alle Schrauben eingesetzt haben, schrauben Sie

sie erst vorsichtig fest.

- Prüfen Sie regelmäßig den festen Sitz der Schrauben und Verbindungen, falls notwendig nachziehen.

## Warnhinweise

- Halten Sie Kinder bei der Montage fern, da Kleinteile bei Verschlucken oder Einatmen tödlich sein können.
- Um mögliche Körperverletzungen zu vermeiden, ist es Kindern verboten, auf diesem Produkt zu klettern oder damit zu spielen.
- Schützen Sie Ihre Kinder von Verpackungsteile wie Folien oder Plastikbeutel fern, da Verpackungsteile oft nicht erkennbare Gefahren bergen (z. B. Erstickungsgefahr).
- Halten Sie spitze Gegenstände und ätzende Chemikalien vom Produkt fern, da diese die Oberfläche beschädigen können.
- Die max. Belastbarkeit beträgt 200 kg. Legen Sie bitte keine zu schweren Gegenstände auf das Produkt.

---

FR

## Introduction

- Lisez attentivement ces instructions et utilisez votre produit d'après ce mode d'emploi.
- Conservez ces instructions. Si vous souhaitez offrir ce produit à un tiers, joignez obligatoirement ce mode d'emploi.
- Pour des raisons de clarté, les détails concernant chaque variante ou montage envisageable ne peuvent être tous décrits. Si vous souhaitez obtenir plus d'informations ou si vous rencontrez certains problèmes non traités de manière détaillée dans ces instructions, veuillez nous contacter.

## Notes

- Veuillez respecter scrupuleusement les étapes à montage soulignées dans ce mode d'emploi, surtout ne pas modifiez ni bricolez ce produit. Le vendeur n'assume aucune responsabilité pour les dommages causés par un assemblage incorrect ou une utilisation non conforme.
- Ce produit est conçu uniquement pour un usage à l'intérieur. Ne placez pas ce produit dans un endroit humide pendant une longue durée pour éviter de la moisissure.
- Lors du montage, veuillez positionner et régler bien toutes les vis et les clous, ensuite effectuez un serrage progressif de l'ensemble des vis.
- Nous vous invitons à vérifier régulièrement les vis qui pourraient se desserrer pendant utilisation. Veuillez assurer que toutes les vis sont bien serrées pour éviter les dommages causés par le renversement.

## Avertissements

- Les enfants ne sont pas autorisés de participer à l'assemblage de ce produit car il comprend nombre de petites pièces. L'inspiration ou l'ingestion de ces pièces présente un risque mortel.
- Ne pas laissez les enfants monter ou jouer sur ce produit pour éviter le renversement.
- Gardez toutes les pièces et l'emballage(films, sacs plastiques, polyester etc.) hors la portée des enfants pour éviter les dangers inattendus(par ex. L'étouffement ).
- Évitez tout contact de ce produit avec des objets pointus ou corrosifs.
- La charge max de ce produit est de 200 kg, veuillez ne pas passer sa limite.

## Linee guida generali

- Si prega di leggere attentamente le seguenti istruzioni e usare il prodotto in modo opportuno.
- Si prega di conservare questo manuale e consegnarlo quando il prodotto cambia proprietario.
- Questo riassunto potrebbe non includere ogni dettaglio di tutte le variazioni e le fasi considerate. Contattaci se hai bisogno di ulteriori informazioni e assistenza.

## Note

- Il prodotto è inteso esclusivamente per uso interno. Deve essere assemblato e usato secondo le istruzioni. Il rivenditore non si assume alcuna responsabilità per danni o infortuni causati da assemblaggio o uso improprio.
- Si prega di evitare esposizione prolungata ad ambienti umidi per prevenire la formazione di muffa.
- Durante l'assemblaggio, allineare prima tutte le viti con i fori corrispondenti, quindi avvitarle una alla volta.
- Controllare regolarmente le viti, potrebbero allentarsi durante l'uso. Se necessario, stringerle di nuovo per garantire stabilità e sicurezza.

## Avvertenze

- Impedire ai bambini di assemblare il prodotto. Durante l'assemblaggio, tenere le parti di piccole dimensioni fuori dalla portata dei bambini, potrebbero essere fatali se ingerite o inalate.
- Impedire ai bambini di salire in piedi, arrampicarsi o giocare sul prodotto per evitare infortuni gravi causati dalla caduta.
- Tenere gli imballaggi di plastica fuori dalla portata dei bambini per evitare qualsiasi potenziale pericolo, come il soffocamento.
- Non portare a contatto con oggetti appuntiti e sostanze chimiche corrosive per prevenire danni al prodotto o lesioni.
- La capacità di carico massima del prodotto è 200 kg. Non appoggiare oggetti oltre questo limite.

## Acerca del manual

- Por favor, lea detenidamente las instrucciones y respete los debidos usos del producto.
- Por favor, conserve bien este manual y en caso de cesión, no omita entregarlo junto al producto.
- Este manual podría no incluir todos los detalles de cada paso del montaje. Si necesita ayuda o información adicional, póngase en contacto con nosotros.

## Notas

- Este producto es sólo para uso interior. Este producto debe ser instalado y utilizado estrictamente de acuerdo con las instrucciones del manual adjunto. La utilización inhabilitada a las instrucciones, o la alteración o modificación no autorizada de este producto son prohibidas, que hayan posibilidades de provocar lesión personal o daños en el producto. El fabricante no asume ninguna responsabilidad con respecto a cualquier daño causado por montaje incorrecto o uso inadecuado.

- Este producto es adecuado para uso interior. No deje el producto en ambiente húmedo por larga duración para evitar la presencia de moho.
- No apriete ninguno de los tornillos durante el ensamblaje. Al completar el ensamblaje, aprieta a la vez todos los tornillos.
- Favor de comprobar regularmente la firmeza de los tornillos. Durante el proceso de utilización, los tornillos en las partes de fijación pueden aflojarse gradualmente. La utilización bajo esta condición puede causar inclinación y daños personales, así que asegúrese de que los tornillos estén bien apretados.

## **Advertencias**

- Durante el montaje, mantenga todos los objetos pequeños fuera del alcance de los niños, ya que pueden ser fatales si se tragan o inhalan.
- Prohíba que los niños suban al producto o jueguen en el producto para evitar las posibles lesiones causadas por la inclinación del producto.
- Mantenga el material de embalaje fuera del alcance de los niños para evitar los peligros potenciales de asfixia.
- No exponga el producto a objetos afilados y sustancias corrosivas para evitar daños al producto o lesiones personales.
- La carga máxima del producto es de 200 kg. No coloque ningún artículo de sobrepeso.

**A**

× 1

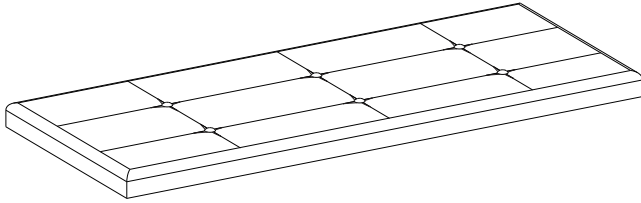

**B**

× 1

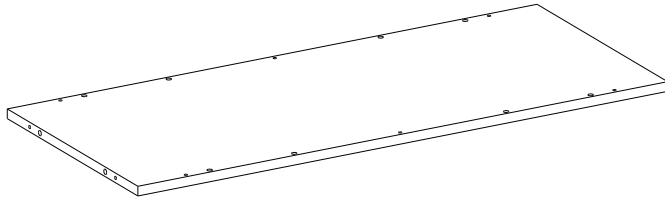

**C**

× 1

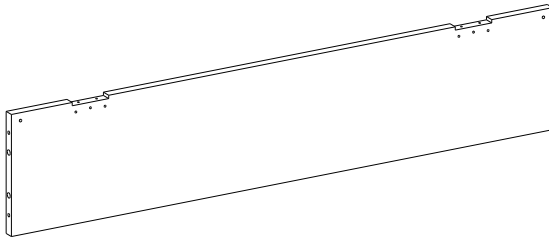



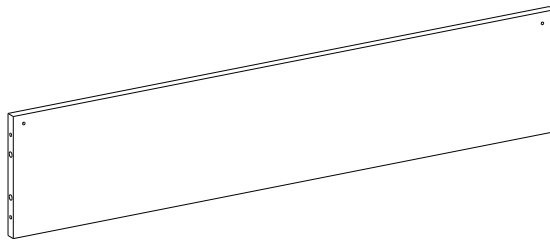

**D**

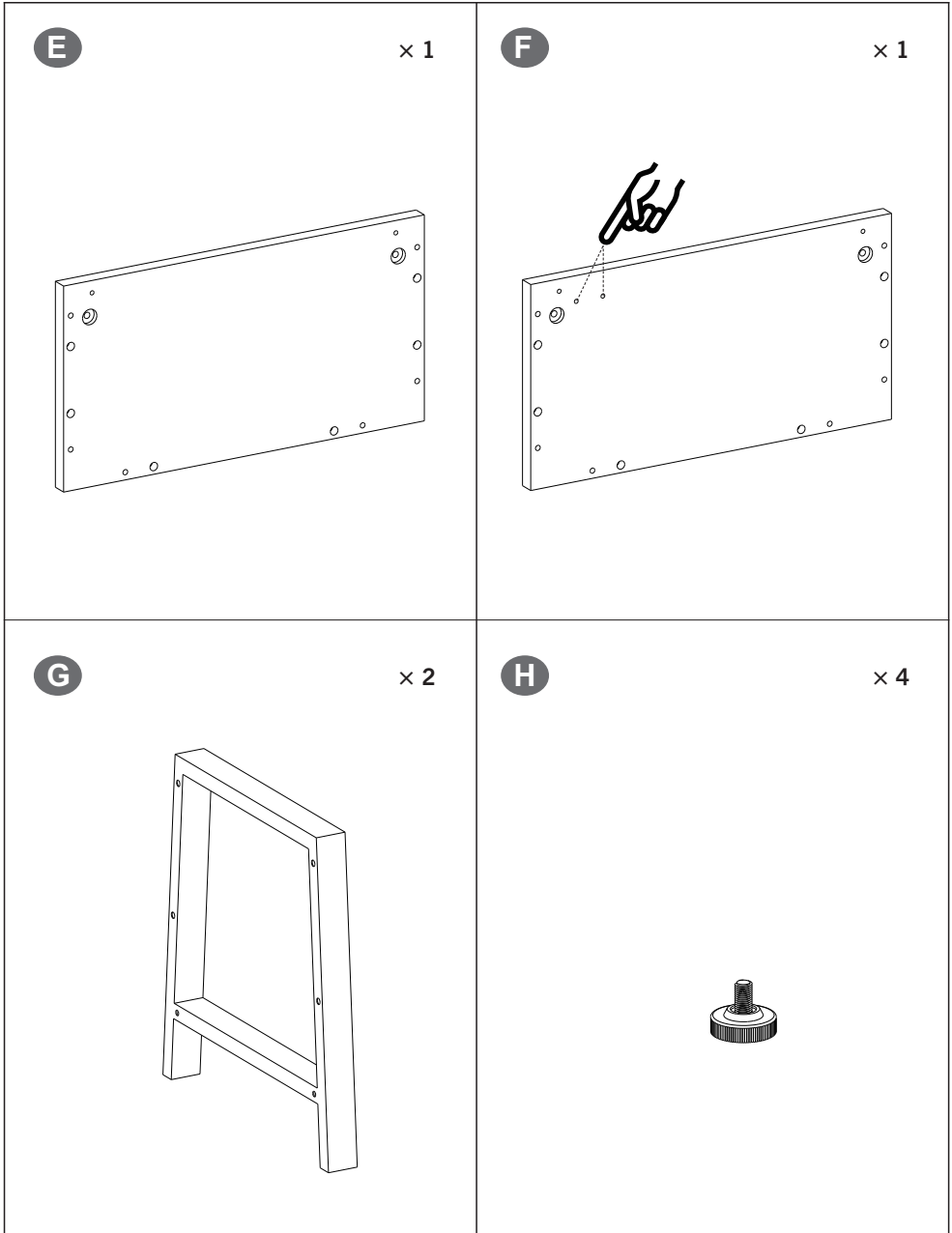

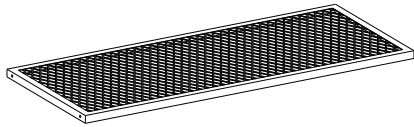
× 1

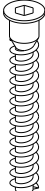
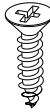
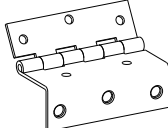
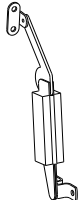



<p><b>I</b> × 1</p> 	<p><b>J</b> × 2</p> 
<p><b>K</b> 20+1</p> 	<p><b>L</b> 18+1</p> 
<p><b>M</b> 28+1</p> 	<p><b>N</b> × 2</p> 
<p><b>O</b> × 1</p> 	<p><b>P</b> 4+1</p>  <p>M6 × 20mm</p>

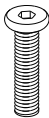
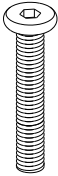
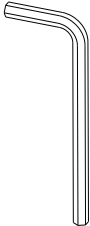
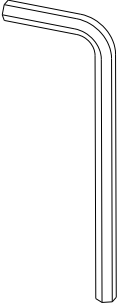

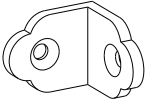
<p><b>Q</b> 4+1</p>  <p>M6 × 30mm</p>	<p><b>R</b> 8+1</p>  <p>M6 × 50mm</p>
<p><b>S</b> × 1</p> 	<p><b>T</b> × 1</p> 
<p><b>U</b> × 1</p> 	<p><b>V</b> × 4</p> 

1

- During assembly, align all screws with the corresponding pre-drilled holes first and then tighten them one by one.

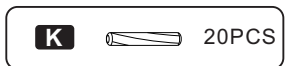
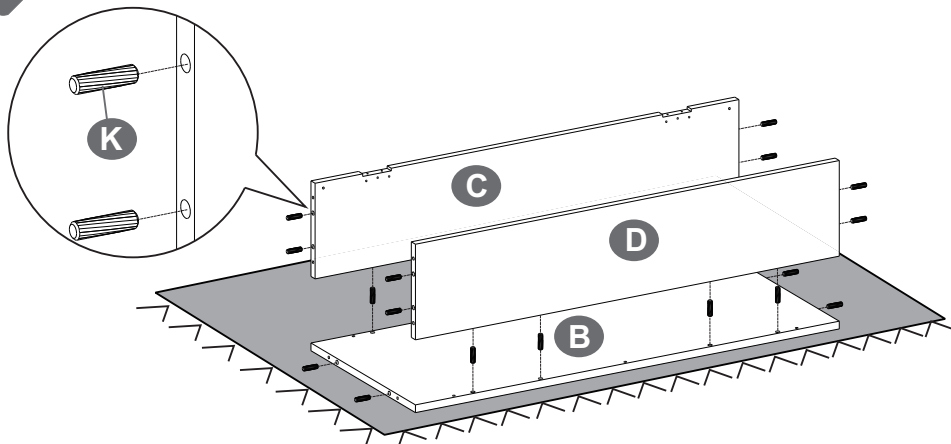

2

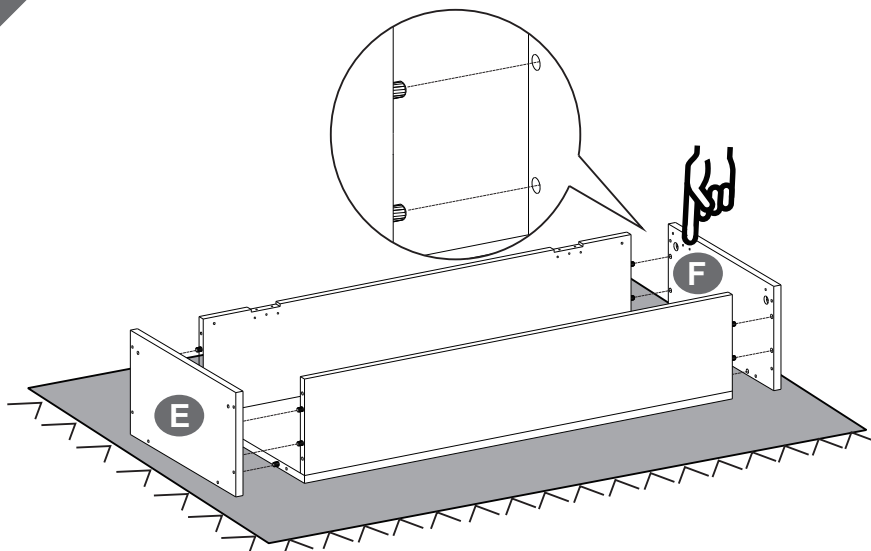

3

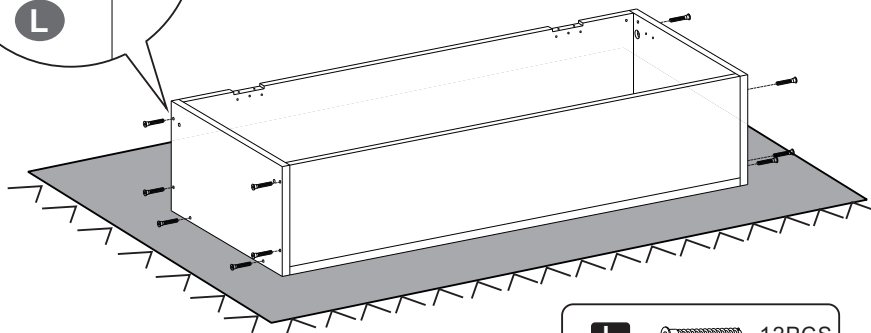
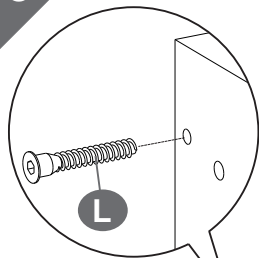

**L**  12PCS

4

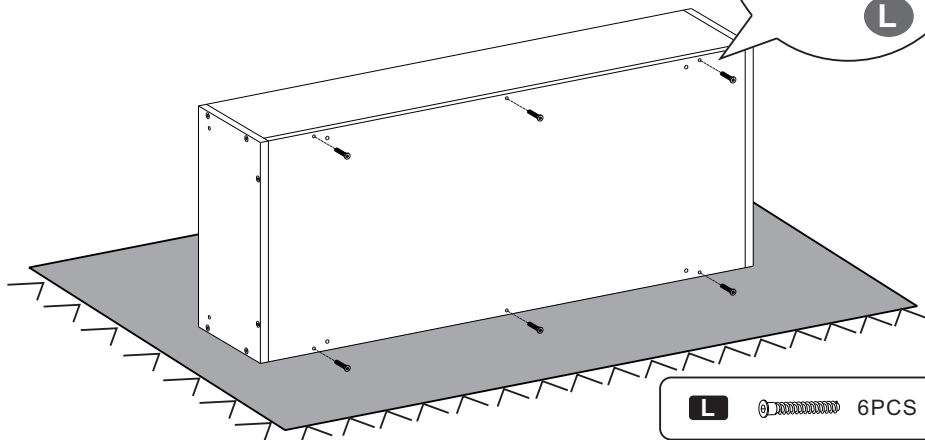
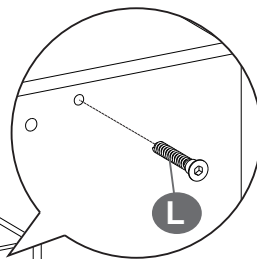

**L**  6PCS

5

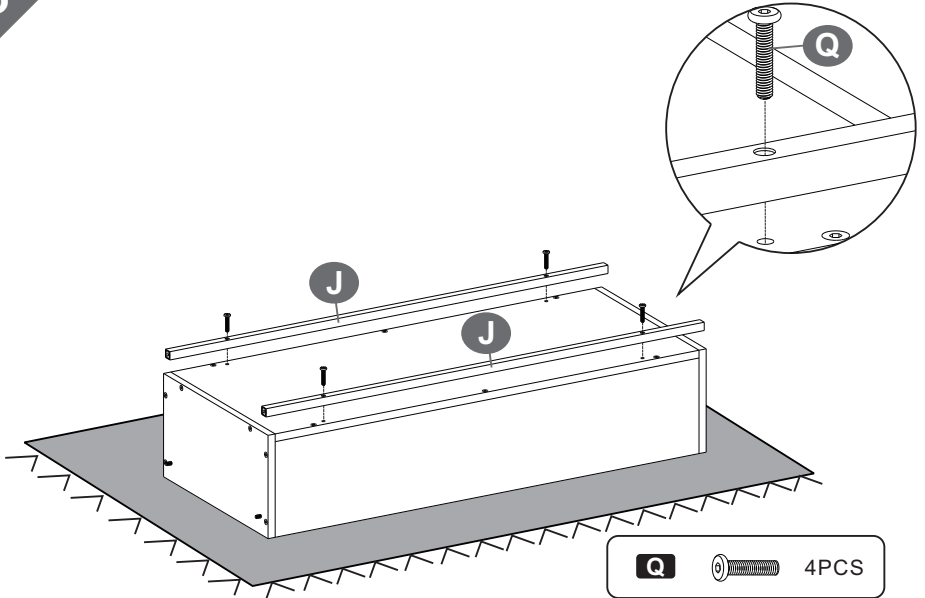

6

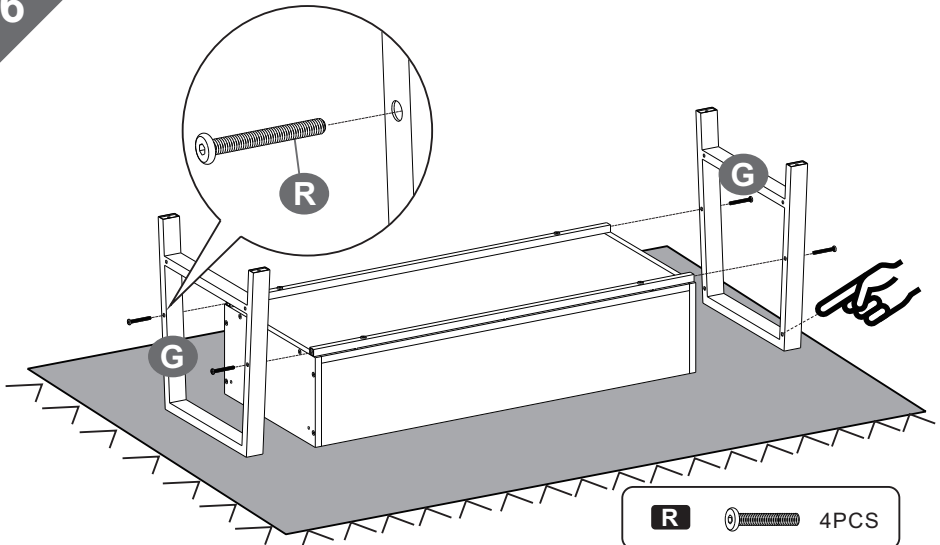

7

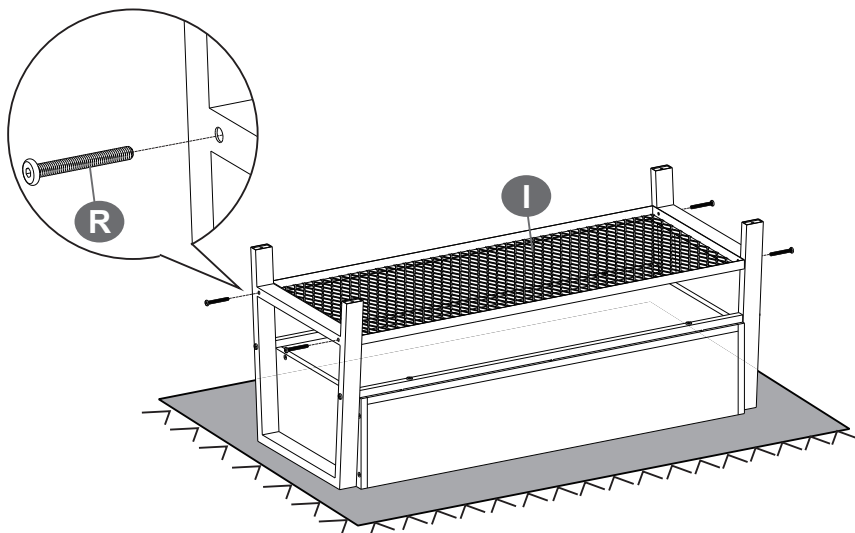

**R**



4PCS

8

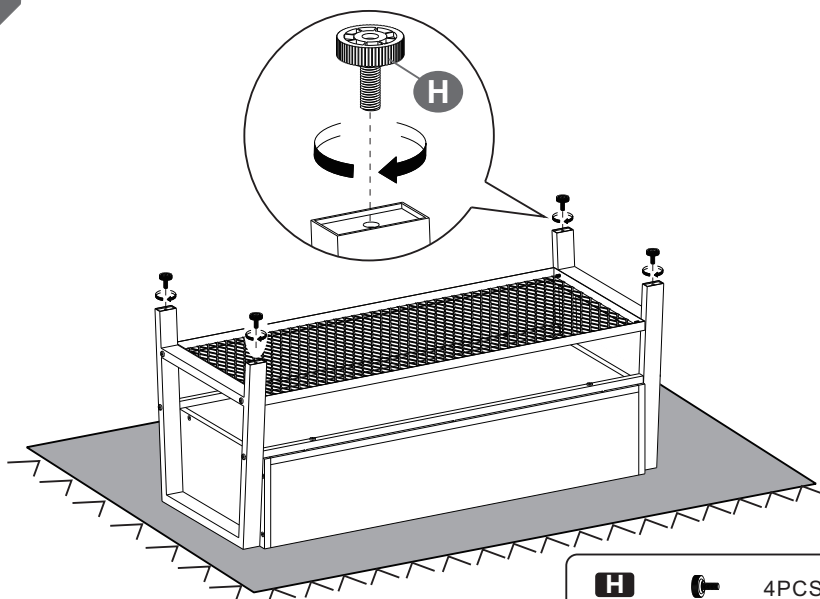

**H**



4PCS

9

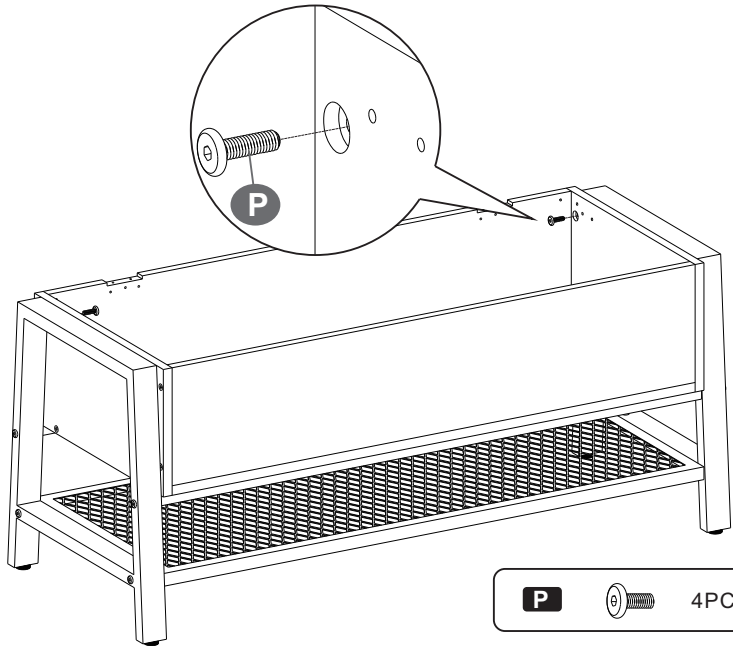

**P**



4PCS

10

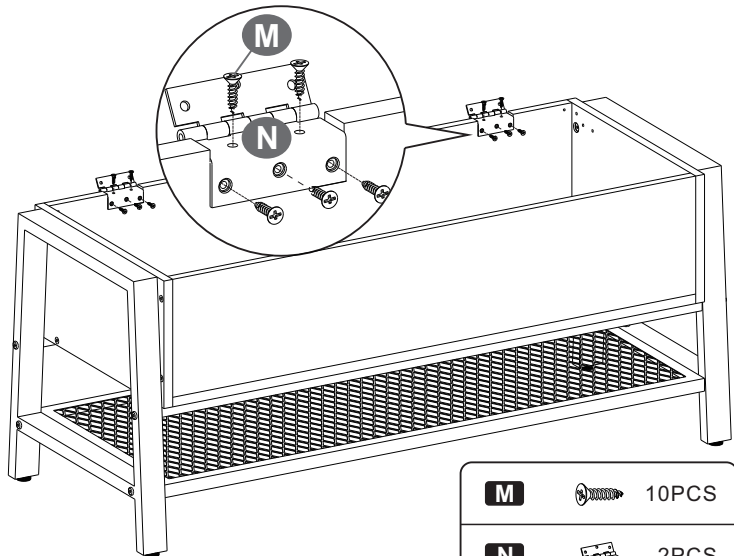

**M**



10PCS

**N**



2PCS

11

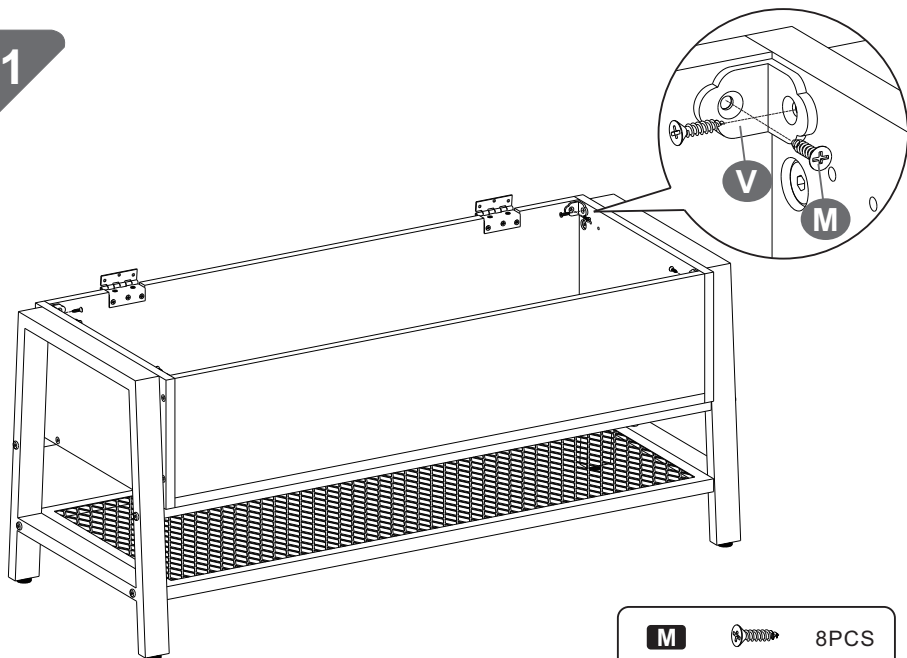

**M**  8PCS

12

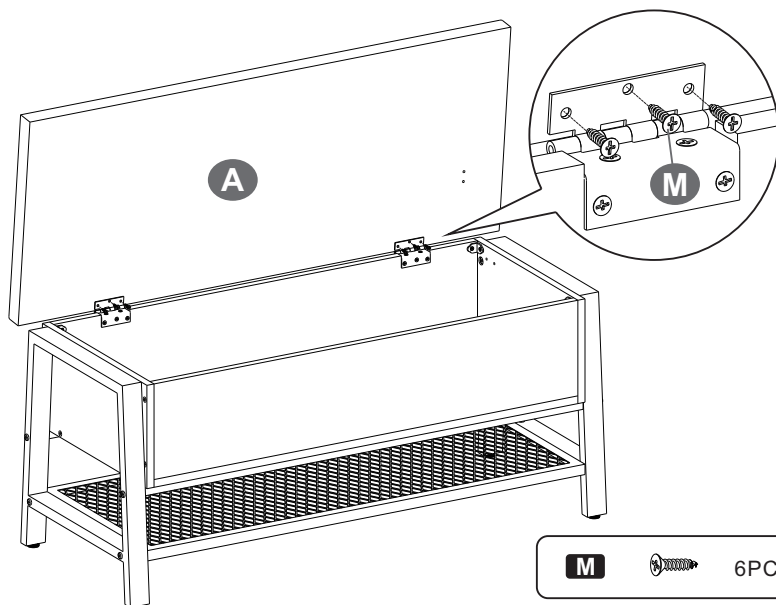

**M**  6PCS

13

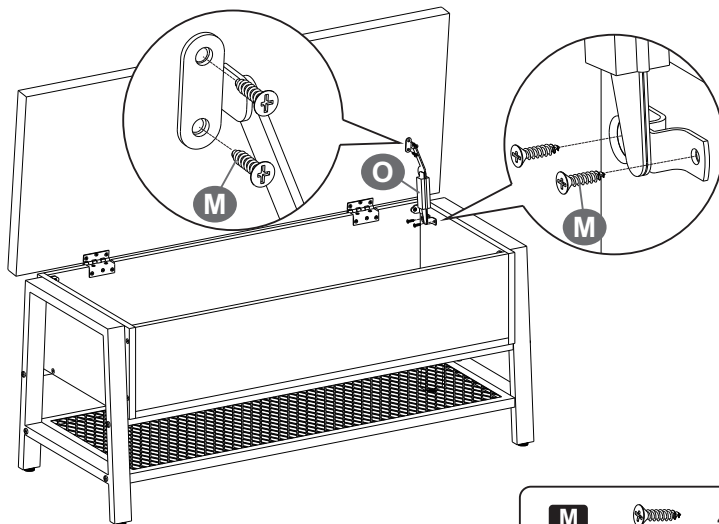

M



4PCS

14

