

# LCR12/012/ 13/013

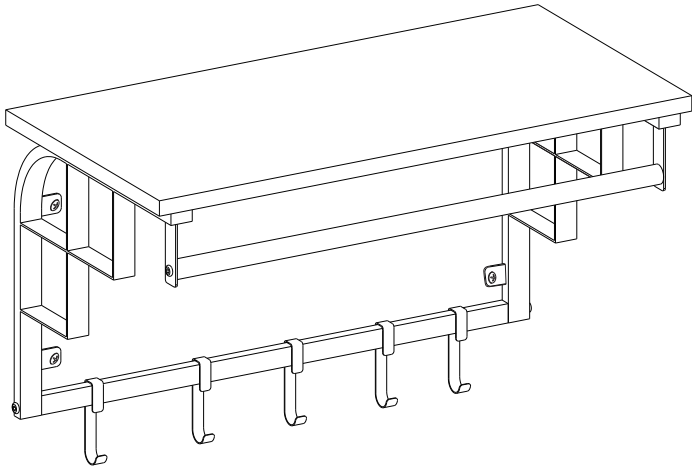

## General Guidelines

- Please read the following instruction carefully and use the product accordingly.
- Please keep this manual and hand it over when you transfer the product.
- This summary may not include every detail of all variations and considered steps. Please contact us when further information and help are needed.

## Notes

- Please assemble this item strictly according to the steps in the instructions.
- Product should be mounted to the wall.
- Make sure the product is fixed to the wall securely after installation.
- Considering various types of walls, you may need to purchase the appropriate fittings from a professional dealer.
- The maximum load capacity of each hook is 6.6 lbs (3 kg), board is 22 lbs (10 kg) and the hanging rail holds 22 lbs (10 kg).

## Warnings

- If there are defective or missing parts, please do not use the product to avoid potential hazards.
- If the product comes loose from the wall during use, please fix it immediately to avoid the product falling down.

## Einleitung

- Bitte lesen Sie die folgende Anleitung aufmerksam durch und verwenden Sie das Produkt sachgemäß.
- Bewahren Sie diese Anleitung gut auf und händigen Sie sie bei Weitergabe des Produkts an Dritte ebenfalls mit aus.
- Aus Gründen der Übersicht können nicht alle Details zu allen Varianten und denkbaren Montagen beschrieben werden. Wenn Sie weitere Informationen und Hilfe benötigen, kontaktieren Sie uns bitte.

## Hinweise

- Bauen Sie das Produkt bitte streng nach der Anleitung auf.
- Das Produkt sollte an der Wand montiert werden.
- Überprüfen Sie den festen Halt des Produkts nach der Montage.
- Aufgrund der Vielzahl von vorhandenen Wandkonstruktionen und Materialien kann es notwendig sein, entsprechend Ihres Mauerwerks passende Schrauben über den Fachhandel zu beziehen.
- Die max. Belastbarkeit jedes Hakens beträgt 3 kg, die max. Tragkraft der Platte ist 10 kg und der Stange 10 kg.

## Warnhinweise

- Benutzen Sie das Produkt nicht, wenn Teile fehlen oder beschädigt sind.
- Sollte sich das Produkt während des Gebrauchs von der Wandfläche lösen, befestigen Sie es bitte rechtzeitig wieder, um ein Herunterfallen des Produktes zu vermeiden.

FR

## Introduction

- Lisez attentivement ces instructions et utilisez votre produit d'après ce mode d'emploi.
- Conservez ces instructions. Si vous souhaitez offrir ce produit à un tiers, joignez obligatoirement ce mode d'emploi.
- Pour des raisons de clarté, les détails concernant chaque variante ou montage envisageable ne peuvent être tous décrits. Si vous souhaitez obtenir plus d'informations ou si vous rencontrez certains problèmes non traités de manière détaillée dans ces instructions, veuillez nous contacter.

## Notes

- Veuillez suivre scrupuleusement les instructions du mode d'emploi pour le montage.
- Le produit doit être fixé au mur.
- Vérifiez la bonne tenue du produit après l'installation.
- En raison de la diversité de construction des murs et des matériaux disponibles, il est nécessaire d'acheter des vis adaptées à votre maçonnerie auprès de revendeurs spécialisés.
- La capacité de charge maximale de chaque crochet est de 3 kg, la capacité de charge maximale de la tablette est de 10 kg et de la tringle 10 kg.

## Avertissements

- N'utilisez jamais un produit endommagé ou avec des pièces manquantes, car il existe un risque de blessure.
- Si le produit se détache de la surface du mur pendant l'utilisation, veuillez le rattacher à temps pour éviter qu'il ne tombe.

IT

## Linee guida generali

- Si prega di leggere attentamente le seguenti istruzioni e usare il prodotto in modo opportuno.
- Si prega di conservare questo manuale e consegnarlo quando il prodotto cambia proprietario.
- Questo riassunto potrebbe non includere ogni dettaglio di tutte le variazioni e le fasi considerate. Contattaci se hai bisogno di ulteriori informazioni e assistenza.

## Note

- Installare il prodotto rigorosamente secondo le istruzioni.
- Il prodotto deve essere installato a parete per l'uso.

- Controllare che il prodotto sia fissato saldamente dopo l'installazione.
- A causa dell'elevato numero di strutture e materiali disponibili, potrebbe essere necessario acquistare le viti adatte per la muratura presso un rivenditore specializzato.
- La portata massima di ogni gancio è 3 kg, la portata massima della piastra è 10 kg e 10 kg per la barra.

## Avvertenze

- Non usare il prodotto in caso di parti mancanti o danneggiate.
- Se durante l'uso il prodotto staccasi dalla superficie della parete, rifissare il prodotto in tempo per evitare che cada.

---

ES

## Acerca del manual







- Por favor, lea detenidamente las instrucciones y respete los debidos usos del producto.
- Por favor, conserve bien este manual y en caso de cesión, no olvide entregarlo junto al producto.
- No es posible que presente todos los detalles y los pasos de montaje en las instrucciones. Si necesita ayuda o información adicional, póngase en contacto con nosotros.

## Notas

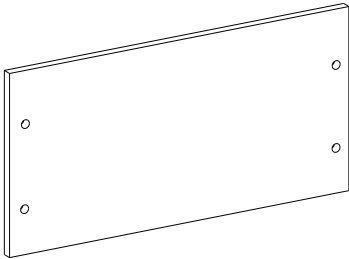
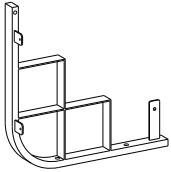
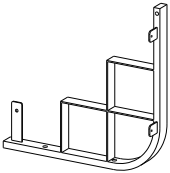
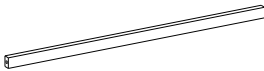
- Por favor, monte el producto siguiendo las instrucciones paso a paso estrictamente.
- El producto debe montarse en la pared.
- Asegúrese de que el producto esté firmemente sujeto después de la instalación.
- Debido a los materiales varios de las paredes, es posible que sea necesario usar los tornillos adecuados. Si es la pared especial, consulte a una ferretería profesional.
- La carga máxima de cada gancho es de 3 kg, la carga máxima de tablero es de 10 kg, la carga máxima de la barra es de 10 kg.

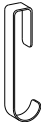
## Advertencias

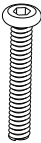
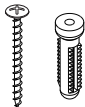
- Cuando se encuentre alguna pieza defectuosa o dañada no utilice el producto, para evitar peligros potenciales.
- Si el producto está suelto en la pared, por favor, vuelva a fijarlo oportunamente para evitar que se caiga.

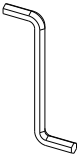
<b>A</b>  × 1	<b>B</b>  × 1	
<b>C</b>  × 1	<b>D</b>  × 1	<b>E</b>  × 1
<b>F</b>  × 5	<b>G</b>  × 4	<b>H</b>  × 4
<b>I</b>  × 4	<b>J</b>  × 4	<b>K</b>  × 1

tools required:

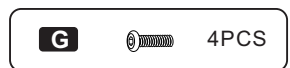
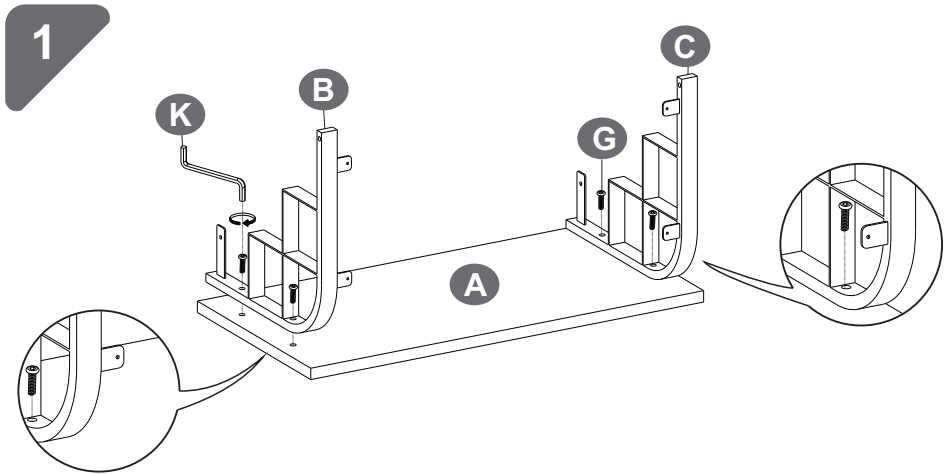
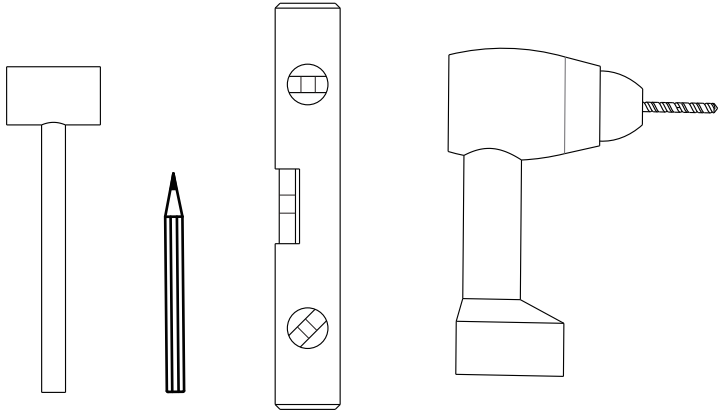

2

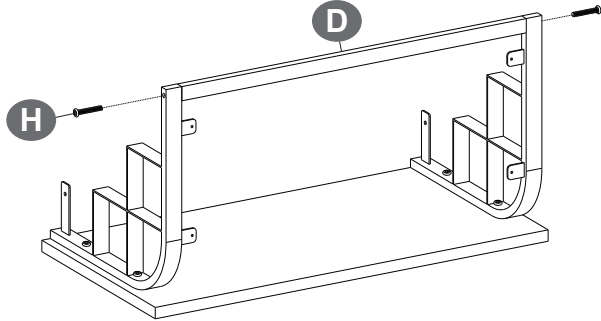

**H**



2PCS

3

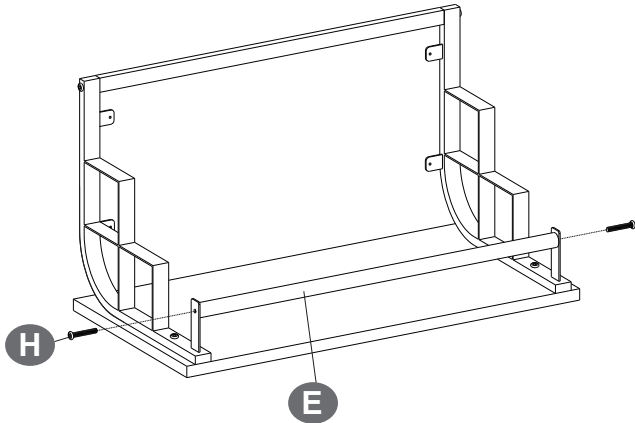

**H**



2PCS

4

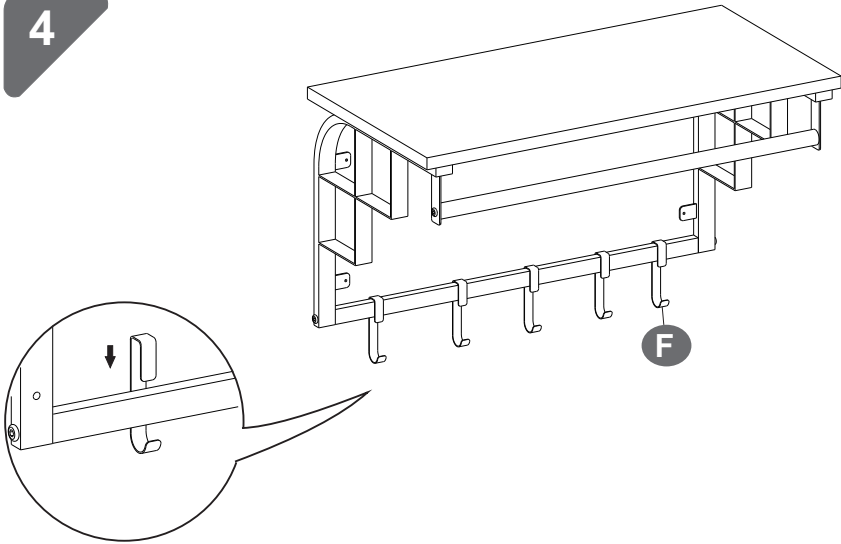

5

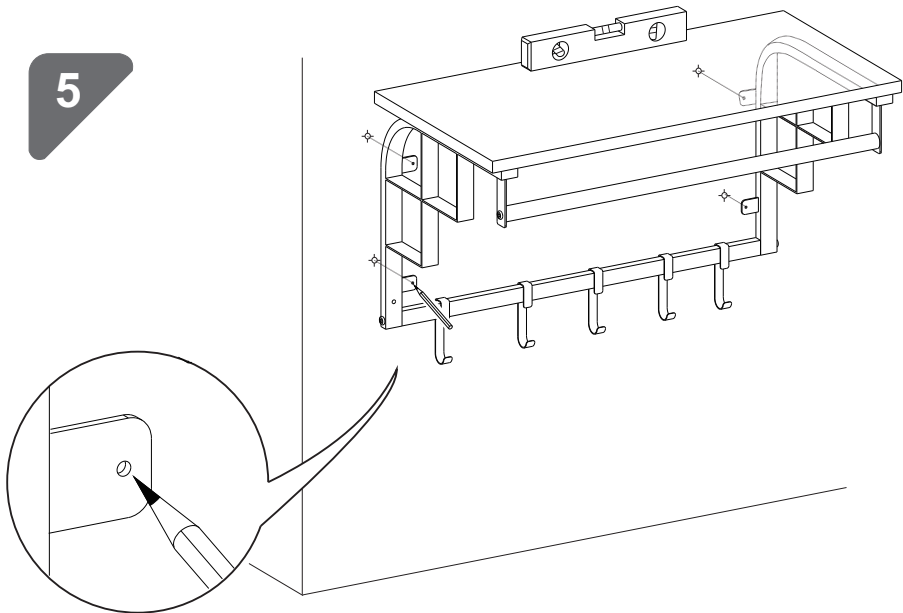



6

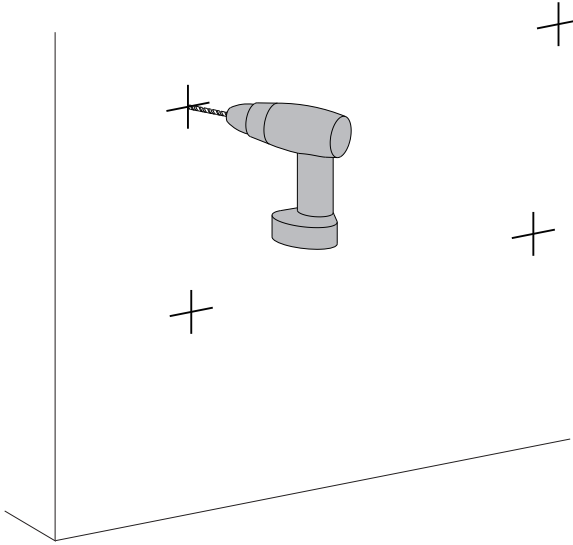

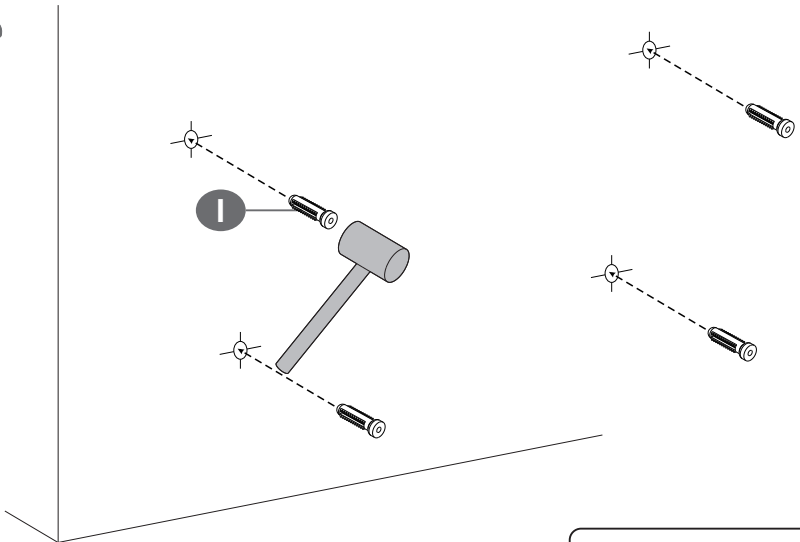

7

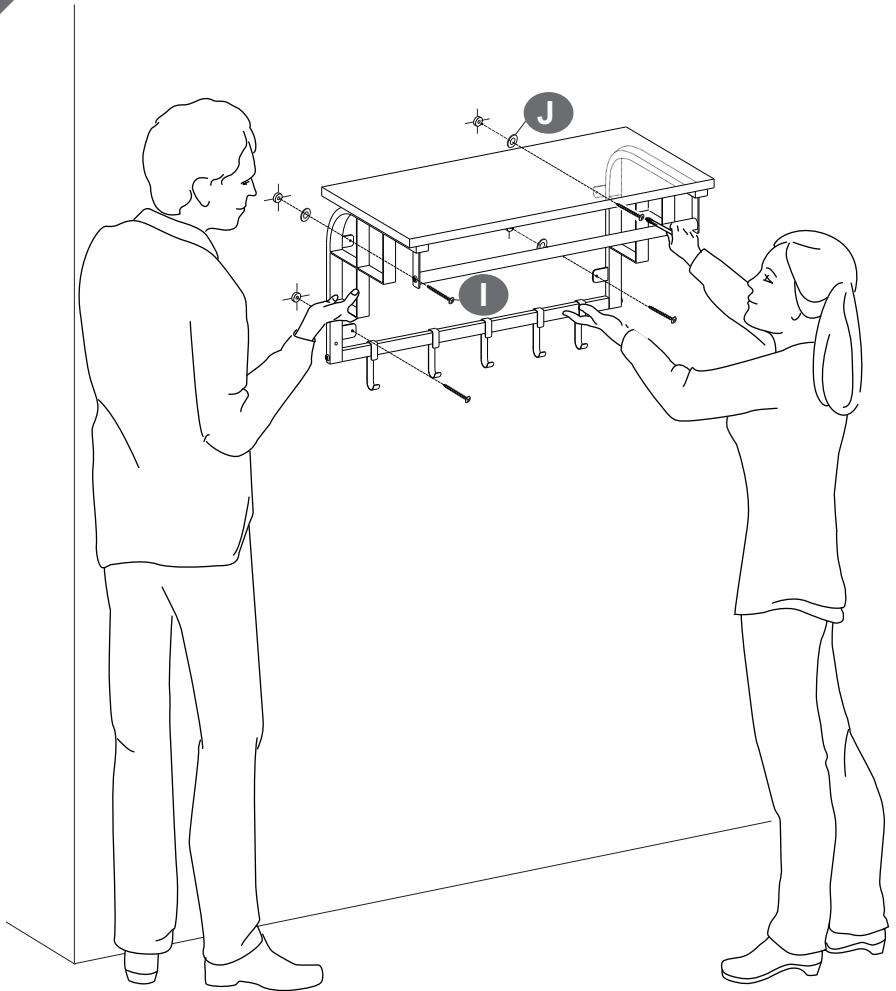

4PCS

8



<b>J</b>		4PCS
<b>I</b>		4PCS